

# Voltage/Current Forcing Module [VFIF-16]

- Output Voltage: ±100V
- Output Current: ±200mA
- Output Power: 20W
- 16-Bit Precision DAC's
- Programmable Bipolar Current & Voltage
- 8 Current Ranges: 100nA to 1A Full Scale
- 6 Voltage Ranges: 2.5V to 100V Full Scale
- Indefinite Short Circuit Protection
- Kelvin Sensing

The VFIF-16 is a programmable voltage/current source that can supply a load current of ±200mA at voltages of ±100VDC. VFIF's are the primary supplies in Reedholm test systems. One must be addressed as PS#1 for any Reedholm software to run. Except for electromigration (RI-52) and time dependent dielectric breakdown (RI-51) systems, applications software requires at least two VFIF's addressed as PS#1 and PS#2. The other two supplies can be VF's.

## Basic Operation

The VFIF-16 (figure 1) consists of two precision DAC's, an error amplifier, precision voltage clamp, voltage controlled current source (VCCS), power output stage, sense buffer amplifier, and precision feedback components.

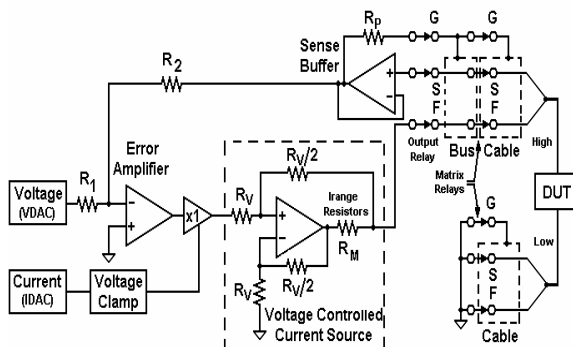

Figure 1 - VFIF-16 Block Diagram

Specifications				
Mode	Range	Source Error		Resolution
		Offset	% of Value	
Voltage	2.5V	250µV	0.014	78.125µV
	5V	500µV		156.25µV
	10V	1mV		312.5µV
	25V	2.5mV		781.25µV
	50V	5mV		1.5625mV
	100V	10mV		3.125mV
Current	100nA	125pA	0.02	1.5625pA
	1µA	125pA		15.625pA
	10µA	500pA		156.25pA
	100µA	5nA		1.5625nA
	1mA	50nA		15.625nA
	10mA	500nA		156.25nA
	100mA	5µA		1.5625µA
	1A	50µA		0.05

**Comments:**

- 1) Range offset errors apply for a 24-hour period after SelfCal and for temperature changes <±1°C.
- 2) Gain factor (% of value) errors apply after running SelfCal with an ideal (<±10ppm uncertainty) transfer DMM. Actual performance is calculated using <http://www.reedholm.com/SuppNote/SN-115.pdf>.
- 3) Current specifications apply up to 200mA. Active limiting begins at approximately ±203mA.
- 4) CMRR: In current mode, <±0.0002% of range per volt of output
- 5) Accuracy on lowest two current ranges is measured with line cycle integration.
- 6) Current accuracy on a given range has uncertainty of ± (offset error + % of value error). For example, forcing 100µA on the 100µA range results in:  

$$I_{out} = 100\mu A \pm (5nA + 0.02\% \text{ of } 100\mu A)$$

$$I_{out} = 100\mu A \pm 25nA$$
- 7) Voltage accuracy uncertainty is ± (offset error + % of value error). For example, forcing 1V on the 2.5V range results in:  

$$V_{out} = 1V \pm (250\mu V + 0.014\% \text{ of } 1V)$$

$$V_{out} = 1V \pm 390\mu V$$

The error amplifier provides sufficient closed loop gain to ensure that its negative input is at virtual ground when the DUT load current is less than the programmed current limit.

When the VFIF output current is less than the programmed limit, output voltage is determined by the ratio R2/R1, feedback through the sense buffer, and output from a 16-bit precision VDAC with full-scale ranges of ±2.5V, ±5.0V, or ±10V

Since the ratio of R2/R1 can be programmed to be one or ten, and since the VDAC has three ranges, the VFIF-16 has six voltage ranges (2.5, 5, 10, 25, 50, and 100V).

## Output Current

The voltage clamp reference is produced by the 16-bit precision IDAC, which outputs a programmable voltage between 0 and 10V. This clamp reference ensures that the input to the VCCS never exceeds the magnitude of the IDAC voltage.

Because the precision feedback resistors ( $R_V/2$ ) are one-half the value of the input and ground resistors ( $R_V$ ), output current is equal to one-half of IDAC voltage output (i.e., 5V maximum) divided by the metering resistor represented by  $R_M$ . There are actually eight metering resistors ( $50M\Omega$  to  $5\Omega$ ), one for each of eight current ranges: 100n, 1 $\mu$ , 10 $\mu$ , 100 $\mu$ , 1m, 10m, 100m, and 1A.

## Sense Buffer

A sense buffer ensures that VFIF output voltage is not affected by voltage drops on the force (F) line. Because the sense buffer requires very little input current, the buffer ensures that all of the VCCS output current flows to the DUT load. This buffer also provides Kelvin sensing.

The VFIF-16 can be connected to any of five analog nodes on the backplane via a three-pole switch. This provides accuracy enhancement of Kelvin sensing within a fully encompassing guard shield.

## Short Circuit Protection

Although the VFIF-16 can supply up to 200mA to the DUT, it is fully protected against an output short circuit because output current cannot exceed 240mA under any circumstances.

Also, when the output is shorted, heat sinks on the output stage transistors permit the limit of 240mA in either polarity without stressing the transistors or other elements beyond their specifications.

## Time Response

Figure 2 shows that the VFIF-16 short circuit output current step response. Notice that response time with a shorted output is independent of range.

VFIF-16 voltage step response depends on load resistance and current range. That is because loop gain is reduced by the factor,  $1 + R_M/R_L$ , where  $R_M/R_L$  is the ratio of the metering resistance within the current source, VCCS, to the DUT load resistance. Reducing  $R_L$  thus reduces bandwidth and increases step response time.

Figures 3 through 7 show how voltage response varies when load resistance is varied for the lower current ranges (100n, 1 $\mu$ , 10 $\mu$ , 100 $\mu$ , and 1mA) at full-scale current settings. Note that errors are <0.1% in 1msec for  $R_M/R_L$  ratios of 5:1. At higher current settings, it takes even less time to be within 0.1% of final value.

Normalized Short Circuit Output Current Step Response

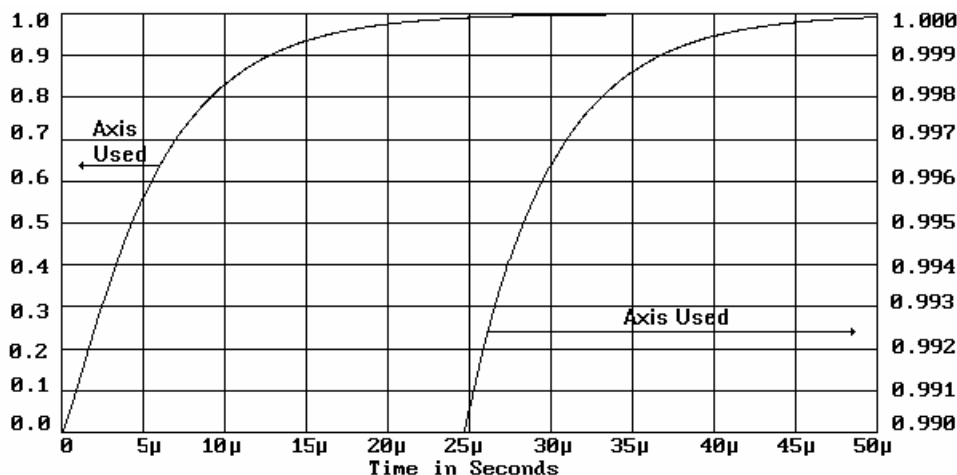

Figure 2 - All Current Ranges

Normalized Output Voltage Step Response  
versus Load Resistance  $R_L$

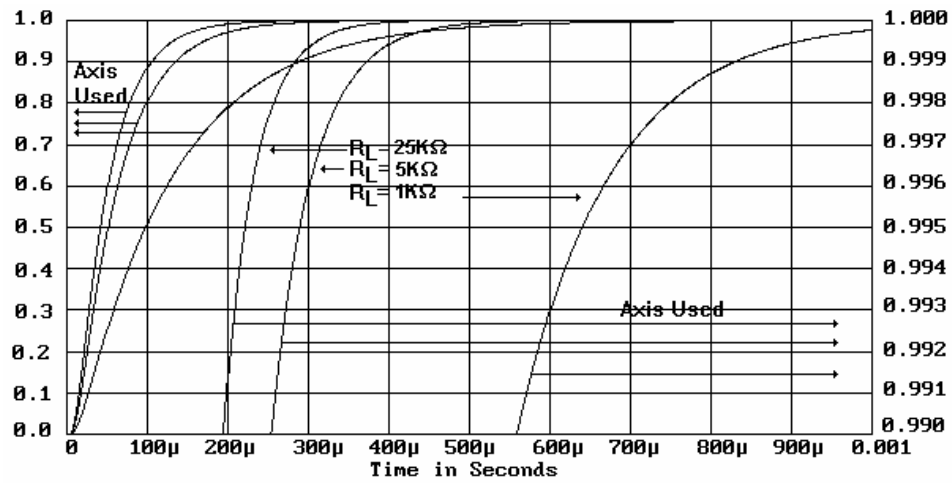

Figure 3 - 1mA Range,  $R_M = 5k\Omega$

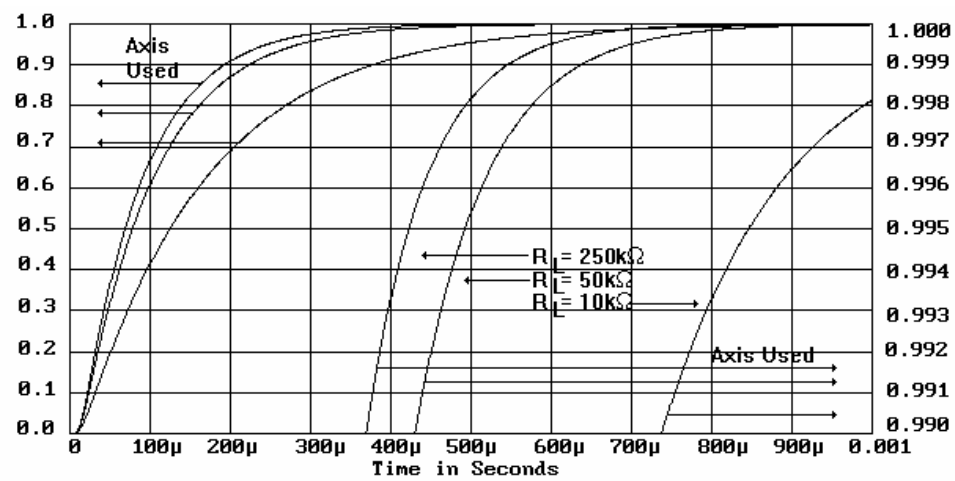

Figure 4 - 100μA Range,  $R_M = 50k\Omega$

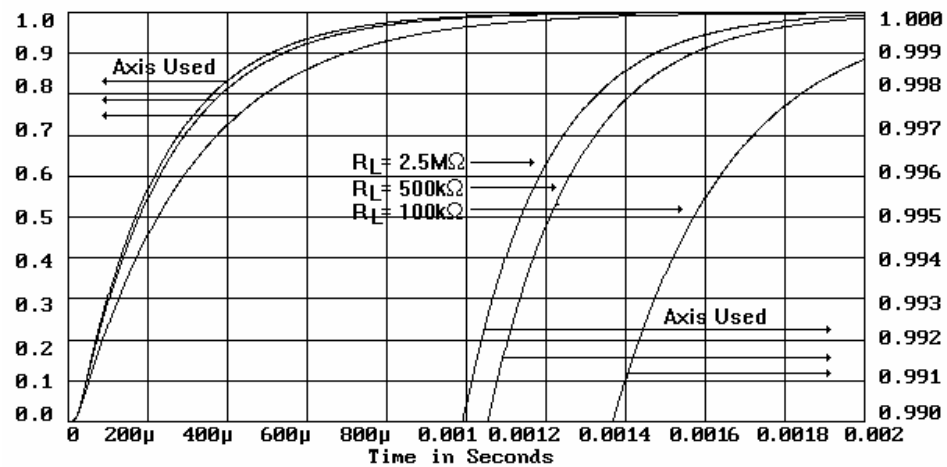

Figure 5 - 10μA Range,  $R_M = 500k\Omega$

Normalized Output Voltage Step Response  
versus Load Resistance  $R_L$

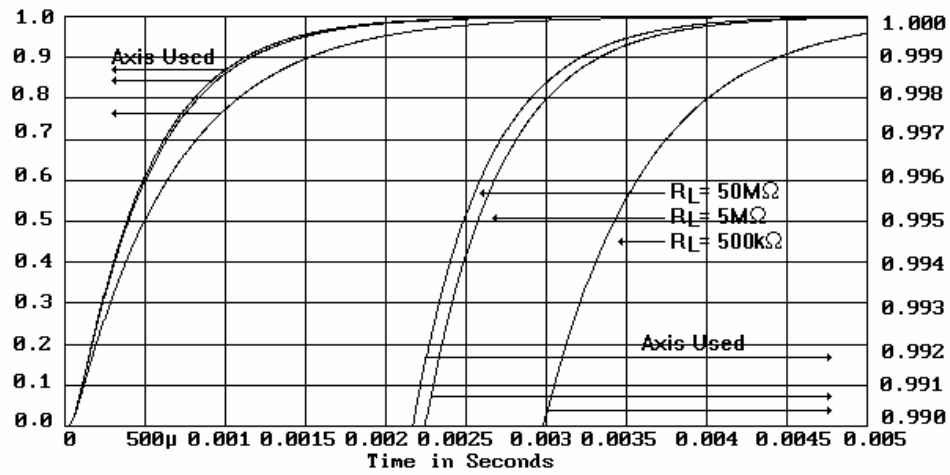

Figure 6 –  $1\mu\text{A}$  Range,  $R_M = 5\text{M}\Omega$

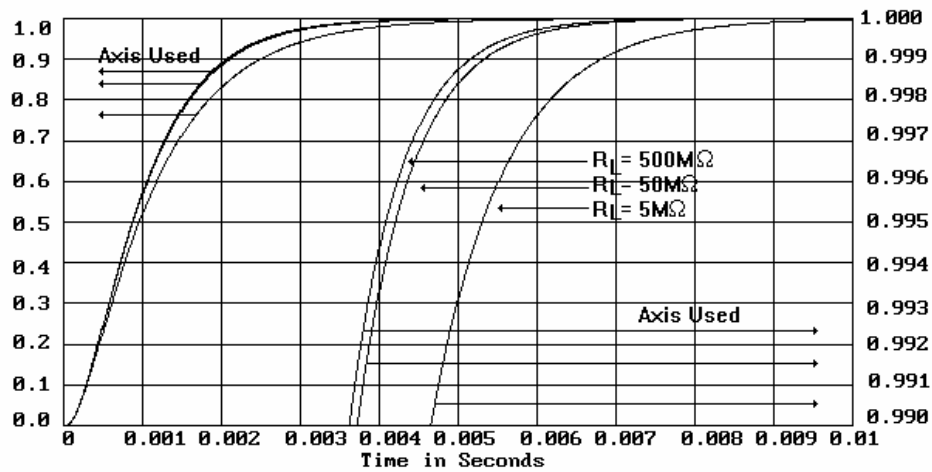

Figure 7 -  $100\text{nA}$  Range,  $R_M = 50\text{M}\Omega$